



# Kraftfahrt-Bundesamt

DE-24932 Flensburg

---



## MITTEILUNG

Ausgestellt von:

**Kraftfahrt-Bundesamt**

über die Erweiterung der Genehmigung  
für einen Schutzhelmtyp mit Visiertyp(en) nach der Regelung Nr. 22

## COMMUNICATION

Issued by:

**Kraftfahrt-Bundesamt**

concerning approval extended  
of a type of protective helmet with visor type(s) pursuant to Regulation  
No. 22

Nummer der Genehmigung: **05300511**  
Approval No.:

Erweiterung Nr.: **02**  
Extension No.:

1. Fabrik- oder Handelsmarke:  
Trade name or mark:  
**LS2, MHR, TAKAI**

2. Typ:  
Type:  
**FF1300**

**Ausführungen/ versions:**  
**1, 2**

Handelsbezeichnung(en):  
General commercial description(s):  
**FF1300, FF397**

3. Größen:  
Sizes:  
**XXS(51/52), XS(53/54), S(55/56), M(57/58), L(59/60), XL(61/62),  
XXL(63/64), XXXL(65/66)**



# Kraftfahrt-Bundesamt

DE-24932 Flensburg

---

2

Nummer der Genehmigung: 05300511, Erweiterung 02  
Approval No.:

4. Name des Herstellers:  
Manufacturer's name:  
**JIANGMEN PENGCHENG HELMETS LTD.**  
**CN-Gonghe Town, Heshan City**
5. Anschrift:  
Address:  
**(s. 4.)**
6. Gegebenenfalls Name des Vertreters des Herstellers:  
If applicable, name of manufacturer's representative:  
**entfällt**  
**not applicable**
7. Anschrift:  
Address:  
**(s. 6.)**
8. Kurze Beschreibung des Helms:  
Brief description of helmet:  
**siehe Anlagen**  
**see enclosures**
9. Helm mit schützender unterer Gesichtsabdeckung **(P)**  
Helmet with protective lower face cover **(P)**
10. Visiertyp oder Visiertypen:  
Type of visor or visors:  
**FF-MHR-80**  
**E1 22R 05300508**
11. Kurze Beschreibung des Visiers oder der Visiere:  
Brief description of visor or visors:  
**siehe Anlagen**  
**see enclosures**
12. Zur Genehmigung vorlegt am:  
Submitted for approval on:  
**04.05.2016**
13. Technischer Dienst, der die Prüfungen für die Genehmigungen durchführt:  
Technical service responsible for conducting approval tests:  
**SGS-TÜV Saar GmbH**  
**DE-81379 München**



# Kraftfahrt-Bundesamt

DE-24932 Flensburg

---

3

Nummer der Genehmigung: 05300511, Erweiterung 02  
Approval No.:

14. Datum des Gutachtens des Technischen Dienstes:  
Date of report issued by that service:  
**03.05.2016**
15. Nummer des Gutachtens des Technischen Dienstes:  
Number of report issued by that service:  
**SHHOM150700204-02**
16. Bemerkungen:  
Comments:  
**entfällt**  
**not applicable**
17. Die Genehmigung wird **erweitert**  
Approval **extended**
18. Ort: **DE-24932 Flensburg**  
Place:
19. Datum: **20.05.2016**  
Date:
20. Unterschrift: **Im Auftrag**  
Signature:

  
(D. Stieglitz)





# Kraftfahrt-Bundesamt

DE-24932 Flensburg

---

4

Nummer der Genehmigung: 05300511, Erweiterung 02  
Approval No.:

21. Folgende mit der oben erwähnten Genehmigungsnummer versehene Dokumente sind auf Anforderung erhältlich.  
The following documents, bearing the approval number shown above, are available on request:

**Nebenbestimmungen und Rechtsbehelfsbelehrung**  
**Collateral clauses and instruction on right to appeal**

**1 Prüfbericht mit Anlagen**  
**1 Test report with appendices**

**1 Beschreibungsmappe R22-FF1300-02 (19 Blatt)**  
**1 Information folder R22-FF1300-02 (19 sheets)**



# Kraftfahrt-Bundesamt

DE-24932 Flensburg

---

Nr. der Genehmigung: 05300511, Erweiterung 02  
Approval No.:

## - Anlage -

### **Nebenbestimmungen und Rechtsbehelfsbelehrung**

#### **Nebenbestimmungen**

Die Einzelerzeugnisse der reihenweisen Fertigung müssen mit den Genehmigungsunterlagen genau übereinstimmen. Die in der bisherigen Genehmigung enthaltenen Auflagen gelten auch für diese Erweiterung.

#### **Rechtsbehelfsbelehrung**

Gegen diese Genehmigung kann innerhalb eines Monats nach Bekanntgabe Widerspruch erhoben werden. Der Widerspruch ist **beim Kraftfahrt-Bundesamt, Fördestraße 16, DE-24944 Flensburg**, schriftlich oder zur Niederschrift einzulegen.

## - Attachment -

### **Collateral clauses and instruction on right to appeal**

#### **Collateral clauses**

The individual production of serial fabrication must be in exact accordance with the approval documents. The requirements contained in the previous approval are also valid for this amendment.

#### **Instruction on right to appeal**

This approval can be appealed within one month after notification. The appeal is to be filed in writing or as a transcript at the **Kraftfahrt-Bundesamt, Fördestraße 16, DE-24944 Flensburg**.

---

# Technical Report

Test standard:  
**ECE Regulation No. 22**

Level of amendment:  
**Supplement 2 to the 05 series of amendments**

Name of test standard  
**Protective helmets and their visors**

---

Manufacturer:  
**Jiangmen Pengcheng Helmets Co., Ltd.**

Type:  
**FF1300**

---

Subject of testing:  
Component



---

**0 General:**

0.1	Make (trade name of manufacturer):	LS2, MHR, TAKAI
0.2	Type:	FF1300
0.2.1	Commercial description(s):	FF1300, FF397
0.3	Means of identification of type, if marked on the vehicle / component / technical unit:	n.a.
0.3.1	Location of that markings:	n.a.
0.4	Category of vehicle:	n.a.
0.5	Manufacturer's name and address:	Jiangmen Pengcheng Helmets Co., Ltd. Industrial Park East, Gonghe Town, Heshan City Guangdong Province, China
0.8	Address of assembly plant:	Jiangmen Pengcheng Helmets Co., Ltd. Industrial Park East, Gonghe Town, Heshan City Guangdong Province, China
0.9	Name and address of representative:	n.a.
	Location of the approval mark:	refer to information document



1 **Test record:**

See appendix

2 **Attachments:**

2.1 List of modifications

2.2 Information folder

No.: **R22-FF1300-02**

Date of issue: **24.03.2016**



**3 Statement of conformity:**

The information folder as mentioned under no. 2.2 and the type described therein are in compliance with the test standard mentioned above.

With regard to the required level of performance to be achieved, the test specimen were representative for the type to be approved.

The tests were carried out in accordance to the relevant requirements of the

EN ISO/IEC 17025:2005     EN ISO/IEC 17020:2012

**Test Laboratory  
SGS-TÜV Saar GmbH**

notified by Kraftfahrt-Bundesamt, Federal Republic of Germany

**KBA - P 00084 - 10**

appointed by National Standards Authority of Ireland

**Technical Service No. 101**

Responsible expert

Conformity check by



Lell Wu

Rose Han

Shanghai, 03.05.2016

This Technical Report shall be reproduced and published in full only and by the client only. It shall be reproduced partially with the written permission of the Test Laboratory only.

This document is issued by the Company under its General Conditions of Service accessible at <http://www.sgs-tuev-saar.com/en/broschueren/AGB-SGS-TUEV-EN.pdf>. Attention is drawn to the limitation of liability, indemnification and jurisdiction issues defined therein. Any holder of this document is advised that information contained hereon reflects the Company's findings at the time of its intervention only and within the limits of Client's instructions, if any. The Company's sole responsibility is to its Client and this document does not exonerate parties to a transaction from exercising all their rights and obligations under the transaction documents. Any unauthorized alteration, forgery or falsification of the content or appearance of this document is unlawful and offenders may be prosecuted to the fullest extent of the law.

**Test record**

**1 Test object and measuring equipment**

**1.1 Test object**

- Protective helmet (without visor)
- Protective helmet (with visor)
- Visor

**1.1.1 Protective Helmet**

Type: FF1300  
 Sizes: XXS(51/52), XS(53/54), S(55/56), M(57/58), L(59/60), XL(61/62), XXL(63/64), XXXL(65/66)

Lower face cover:  Without lower face cover (J)  
 Protective (P)  
 Non protective (NP)

**1.1.2 Helmet visor**

Type: FF-MHR-80  
 Refer to approval no.: E1 22R 05300508

**1.1.3 Sun shade**

The helmet is equipped with a swivel-mounted sun shade, which may only be used in combination with the visor in closed position according to the user manual

- On the inner side of the visor
- On the outer side of the visor
- Not applicable

**1.1.4 Remarks:**

- 1: Fiberglass shell version**
- 2: Carbon fiber shell version**



**1.2 Equipments for measuring and testing:**

**1.2.1 Test equipment:**

The equipment and the test facilities on which the tests were carried out fulfilled the requirements of the ECE Regulation 22.05

**1.2.2 Measurement procedure:**

according to ECE Regulation No. 22.05

<b>2</b>	<b>Test Results</b>	<p>Due to the reason of extension (see attachment 2.1 List of modifications), all tests related were repeated according to this regulation, test results refer to bellow items. The former test results remain valid.</p>										
<b>2.1</b>	<b>Protective helmet</b>											
2.1.1	Marking (clause 4.1.1, 4.4)	<p>All required information, in accordance with the ECE R22.05, is given by the labels</p> <table border="0"> <tr> <td style="border: 1px solid black; width: 20px; text-align: center;">x</td> <td>fulfilled</td> </tr> <tr> <td style="border: 1px solid black; width: 20px;"></td> <td>Not fulfilled</td> </tr> <tr> <td style="border: 1px solid black; width: 20px;"></td> <td>n.a.</td> </tr> </table>	x	fulfilled		Not fulfilled		n.a.				
x	fulfilled											
	Not fulfilled											
	n.a.											
2.1.2	Basic construction (clause 6.1)	<p>Shell + Protective padding + Retention system</p> <table border="0"> <tr> <td style="border: 1px solid black; width: 20px; text-align: center;">x</td> <td>fulfilled</td> </tr> <tr> <td style="border: 1px solid black; width: 20px;"></td> <td>Not fulfilled</td> </tr> <tr> <td style="border: 1px solid black; width: 20px;"></td> <td>n.a.</td> </tr> </table>	x	fulfilled		Not fulfilled		n.a.				
x	fulfilled											
	Not fulfilled											
	n.a.											
2.1.3	If fitted with non protective lower face cover (clause 6.2)	<table border="0"> <tr> <td style="border: 1px solid black; width: 20px;"></td> <td>Marked</td> <td rowspan="3" style="vertical-align: middle; text-align: center;">  </td> </tr> <tr> <td style="border: 1px solid black; width: 20px;"></td> <td>"Does not protect chin from impacts"</td> </tr> <tr> <td style="border: 1px solid black; width: 20px;"></td> <td>Marked with symbol</td> </tr> <tr> <td style="border: 1px solid black; width: 20px; text-align: center;">x</td> <td>n.a.</td> <td></td> </tr> </table>		Marked			"Does not protect chin from impacts"		Marked with symbol	x	n.a.	
	Marked											
	"Does not protect chin from impacts"											
	Marked with symbol											
x	n.a.											
2.1.4	Extent of the protection (clauses 6.4, 6.5)	<p>The shell and the protective padding cover all areas as required</p> <table border="0"> <tr> <td style="border: 1px solid black; width: 20px; text-align: center;">x</td> <td>fulfilled</td> </tr> <tr> <td style="border: 1px solid black; width: 20px;"></td> <td>Not fulfilled</td> </tr> <tr> <td style="border: 1px solid black; width: 20px;"></td> <td>n.a.</td> </tr> </table>	x	fulfilled		Not fulfilled		n.a.				
x	fulfilled											
	Not fulfilled											
	n.a.											

- 2.1.5 Projections / irregularities / sharp edges (clauses 6.6 to 6.9)      All external projections other than press-fasteners are smooth and adequately faired, all external projections which are not more than 2 mm above the outer surface of the shell, have a radius of more than 1 mm, all external projections which are more than 2 mm above the outer surface of the shell have a radius of more than 2 mm.
- All projections or irregularities in the outer surface of the shell which are higher than 2 mm, fulfill the requirements after the shear assessment test. The outer surface of the helmet fulfills the requirements after the friction assessment test.
- There are no inward-facing sharp edges on the inside of the helmet; rigid, projecting internal parts are covered with padding so that any stresses transmitted to the head are not highly concentrated.
- fulfilled  
 Not fulfilled  
 n.a.
- 
- 2.1.6 Test method for projections and surface friction       Procedure A (7.4.1)  
 Procedure B (7.4.2)

Helmet No.	Helmet Size (cm)	Condition	Projections	Friction
M-3	57/58	Solvent plus ambient temperature and hygrometry conditioning	Pass	Pass



---

2.1.7 Peripheral vision (clause 6.14)

Horizontal ( $\geq 105^\circ$ ):

<input checked="" type="checkbox"/>	fulfilled
<input type="checkbox"/>	Not fulfilled
<input type="checkbox"/>	n.a.

Upwards ( $\geq 7^\circ$ ):

<input checked="" type="checkbox"/>	fulfilled
<input type="checkbox"/>	Not fulfilled
<input type="checkbox"/>	n.a.

Downwards ( $\geq 45^\circ$ ):

<input checked="" type="checkbox"/>	fulfilled
<input type="checkbox"/>	Not fulfilled
<input type="checkbox"/>	n.a.

2.1.8 Conspicuity marking  
(clause 6.16)

<input type="checkbox"/>	fulfilled
<input type="checkbox"/>	Not fulfilled
<input checked="" type="checkbox"/>	n.a.

2.1.9 Impact-absorption tests  
 (clause 7.3)

x	fulfilled
	Not fulfilled
	n.a.

Size: 61/62 cm

Test Head Form: O (62 cm)

Helmet No.	Condition	Test anvil	Test site	Velocity (m/s)	Peak 'G ≤275g	HIC ≤2400
XL-1	Solvent plus ambient temperature and hygrometry conditioning	Kerbstone	B	7.55	134.8	947
		Kerbstone	X	7.58	149.3	954
		Flat	P	7.52	173.9	1339
		Flat	R	7.56	175.8	1548
XL-2	Solvent plus ambient temperature and hygrometry conditioning	Flat	B	7.58	175.8	1504
		Flat	X	7.62	201.9	1671
		Kerbstone	P	7.53	228.7	1261
		Kerbstone	R	7.58	166.1	1118
XL-3	Solvent plus heat conditioning	Kerbstone	B	7.52	131.0	922
		Kerbstone	X	7.60	136.4	1021
		Kerbstone	P	7.53	229.1	1223
		Kerbstone	R	7.58	164.2	1102
XL-4	Solvent plus low temperature conditioning	Flat	B	7.59	188.1	1674
		Flat	X	7.61	205.8	1771
		Flat	P	7.56	203.9	1375
		Flat	R	7.58	209.6	1764
		Flat	S	5.50	153.5	584
XL-5	Solvent plus ultra-violet radiation conditioning and moisture conditioning	Kerbstone	B	7.59	176.7	1493
		Flat	X	7.62	153.5	1000
		Flat	P	7.56	170.6	1025
		Kerbstone	R	7.60	189.4	1697

Size: 51/52 cm

Test Head Form: A (50 cm)

Helmet No.	Condition	Test anvil	Test site	Velocity (m/s)	Peak 'G ≤ 275g	HIC ≤ 2400
XXS-1	Solvent plus heat conditioning	Kerbstone	B	7.51	155.6	1103
		Kerbstone	X	7.52	187.8	1328
		Kerbstone	P	7.52	152.2	1014
		Kerbstone	R	7.53	146.1	851
XXS-2	Solvent plus low temperature conditioning	Flat	B	7.51	205.5	1729
		Flat	X	7.52	218.3	1815
		Flat	P	7.51	178.7	1560
		Flat	R	7.54	206.0	1755
		Flat	S	5.51	119.7	323

Size: 53/54 cm

Test Head Form: E (54 cm)

Helmet No.	Condition	Test anvil	Test site	Velocity (m/s)	Peak 'G ≤ 275g	HIC ≤ 2400
XS-1	Solvent plus heat conditioning	Kerbstone	B	7.54	126.9	894
		Kerbstone	X	7.52	146.4	1098
		Kerbstone	P	7.55	156.7	1188
		Kerbstone	R	7.52	220.4	1501
XS-2	Solvent plus low temperature conditioning	Flat	B	7.56	170.0	1481
		Flat	X	7.58	203.7	1728
		Flat	P	7.53	208.3	1814
		Flat	R	7.55	231.3	1996
		Flat	S	5.52	101.0	322

Size: 57/58 cm

Test Head Form: J (57 cm)

Helmet No.	Condition	Test anvil	Test site	Velocity (m/s)	Peak 'G ≤ 275g	HIC ≤ 2400
M-1	Solvent plus heat conditioning	Kerbstone	B	7.50	131.3	918
		Kerbstone	X	7.52	153.8	974
		Kerbstone	P	7.51	161.2	1061
		Kerbstone	R	7.52	179.8	1337
M-2	Solvent plus low temperature conditioning	Flat	B	7.51	213.8	1716
		Flat	X	7.50	212.3	1708
		Flat	P	7.50	185.6	1606
		Flat	R	7.52	217.3	1928
		Flat	S	5.52	128.5	500

Size: 59/60 cm

Test Head Form: M (60 cm)

Helmet No.	Condition	Test anvil	Test site	Velocity (m/s)	Peak 'G ≤ 275g	HIC ≤ 2400
L-1	Solvent plus heat conditioning	Kerbstone	B	7.57	151.0	1183
		Kerbstone	X	7.58	186.6	1089
		Kerbstone	P	7.56	242.7	1406
		Kerbstone	R	7.59	226.7	1393
L-2	Solvent plus low temperature conditioning	Flat	B	7.56	270.6	2226
		Flat	X	7.61	222.4	1762
		Flat	P	7.54	186.6	1508
		Flat	R	7.54	224.1	2131
		Flat	S	5.51	153.8	559

2.1.10 Rigidity test (clause 7.5)

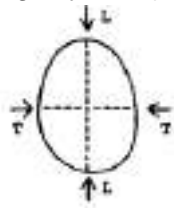

- fulfilled
- Not fulfilled
- n.a.

Helmet No.	Size	Condition	Direction	Max. deformation (≤ 40 mm)	Residual deformation (≤ 15 mm)
XL-6	61/62	Solvent plus ambient temperature and hygrometry conditioning	Longitudinal axis	13.0	1.3
XL-7	61/62	Solvent plus ambient temperature and hygrometry conditioning	Transverse axis	12.4	2.5



---

**2.2 Retention system**

2.2.1 The retention system is protected from abrasion

<input checked="" type="checkbox"/>	fulfilled
<input type="checkbox"/>	Not fulfilled
<input type="checkbox"/>	n.a.

2.2.2 Chin strap  
(clause 6.11.1, 6.11.2)

The width of the chin strap is more than 20 mm under load of 150 N and it doesn't include a chin-cup.

<input checked="" type="checkbox"/>	fulfilled
<input type="checkbox"/>	Not fulfilled
<input type="checkbox"/>	n.a.

2.2.3 Adjustment device  
(clause 6.11.3)

The retention system includes a device to adjust and maintain tension.

<input checked="" type="checkbox"/>	fulfilled
<input type="checkbox"/>	Not fulfilled
<input type="checkbox"/>	n.a.

2.2.4 Fastening devices  
(clauses 6.11.4 to 6.11.9)

The requirements for fastening devices and release mechanisms are in accordance to the requirements of the test standard.

<input checked="" type="checkbox"/>	fulfilled
<input type="checkbox"/>	Not fulfilled
<input type="checkbox"/>	n.a.

2.2.5 Retention system dynamic test  
 (clause 7.6)

fulfilled  
 Not fulfilled  
 n.a.

Helmet No.	Helmet Size (cm)	Condition	Dynamic displacement (≤ 35 mm)	Residual displacement (≤ 25 mm)
XXS-3 With type 1 retention system	51/52	Solvent plus ambient temperature and hygrometry conditioning	25.3	6.6
XXS-4 With type 2 retention system	51/52	Solvent plus ambient temperature and hygrometry conditioning	28.8	6.3
XXS-5 With type 3 retention system	51/52	Solvent plus ambient temperature and hygrometry conditioning	27.4	6.8

2.2.6 Retention (detaching) test  
 (clause 7.7)

fulfilled  
 Not fulfilled  
 n.a.

Helmet No.	Helmet Size (cm)	Condition	Movement of the reference line (≤ 30°)
XXS-3 With type 1 retention system	51/52	Solvent plus ambient temperature and hygrometry conditioning	28°
XXS-4 With type 2 retention system	51/52	Solvent plus ambient temperature and hygrometry conditioning	28°
XXS-5 With type 3 retention system	51/52	Solvent plus ambient temperature and hygrometry conditioning	27°

2.2.7      Micro-slip test of the chin strap  
 (clause 7.9)

x	fulfilled
	Not fulfilled
	n.a.

Slippage of chin strap: (≤ 10mm):      <10 mm

2.2.8      Chin strap, resistance to abrasion test  
 (clause 7.10)

x	fulfilled
	Not fulfilled
	n.a.

2.2.8.1    Chin strap, withstand a tension of 3 kN  
 (clause 7.10.5)

x	fulfilled
	Not fulfilled
	n.a.

2.2.9      Retention systems relying on  
 quick-release mechanisms  
 (clause 7.11)

2.2.9.1    Inadvertent release by pressure  
 (clause 7.11.1)

	fulfilled
	Not fulfilled
x	n.a.

2.2.9.2    Ease of release  
 (clause 7.11.2)

x	fulfilled
	Not fulfilled
	n.a.

2.2.9.3    Durability of quick-release  
 mechanisms (clause 7.11.3)

x	fulfilled
	Not fulfilled
	n.a.

**2.3      Visor**

	n.a. (no visor)
x	n.a. (visor separately approved)

Refer to approval no.: E1 22R 05300508

**2.4 Information for wearers**

(clauses 14.1 to 14.6)

2.4.1 Every protective helmet placed on the market shall bear a clearly visible label with the following inscription in the national language, or at least one of the national languages, of the country of destination:

*"For adequate protection, this helmet must fit closely and be securely attached. Any helmet that has sustained a violent impact should be replaced"*

- fulfilled
- Not fulfilled
- n.a.

and, if fitted with a non protective lower face cover:

*"Does not protect chin from impacts"*

- fulfilled
- Not fulfilled
- n.a.

together with the symbol indicating the unsuitability of the lower face cover to offer any protection against impacts to the chin

2.4.2 and, if hydrocarbons, cleaning fluids, paints, transfers or other extraneous additions affect the shell material adversely

- fulfilled
- Not fulfilled
- n.a.

*"Warning' - Do not apply paint, stickers, petrol or other solvents to this helmet"*

2.4.3 Every protective helmet shall be clearly marked with its size and its maximum weight, to the nearest 50 grammes, as placed on the market. The maximum weight quoted should include all the accessories that are supplied with the helmets, within the packaging, as it is placed on the market, whether or not those accessories have actually been fitted to the helmet.

- fulfilled
- Not fulfilled
- n.a.

- |         |  |  |
|---------|--|--|
| 2.4.4   | Every protective helmet offered for sale shall bear a label showing the type or types of visor that have been approved at the manufacturer's request.  | <input checked="" type="checkbox"/> fulfilled<br><input type="checkbox"/> Not fulfilled<br><input type="checkbox"/> n.a. |
| 2.4.5   | Every visor offered for sale shall bear a label showing the types of protective helmet for which it has been approved  | <input checked="" type="checkbox"/> fulfilled<br><input type="checkbox"/> Not fulfilled<br><input type="checkbox"/> n.a. |
| 2.4.6   | Every visor placed on the market with a protective helmet shall be accompanied by information in the national language, or in at least one of the national languages, of the country of destination. This information shall contain:   |  |
| 2.4.6.1 | General Instruction for Storage and Care   | <input checked="" type="checkbox"/> fulfilled<br><input type="checkbox"/> Not fulfilled<br><input type="checkbox"/> n.a. |
| 2.4.6.2 | Specific instructions for cleaning and their notice of use. These instructions shall include a warning regarding the dangers of using unsuitable agents for cleaning (such as solvents), especially if abrasion resistant coatings are to be preserved.  | <input checked="" type="checkbox"/> fulfilled<br><input type="checkbox"/> Not fulfilled<br><input type="checkbox"/> n.a. |
| 2.4.6.3 | Advice as to the suitability of the visor for use in conditions of poor visibility and during the hours of darkness. The following warning shall be included:<br>Visors with the marking indicating "day-time use only" are not suitable for use during the hours of darkness or in conditions of poor visibility. | <input checked="" type="checkbox"/> fulfilled<br><input type="checkbox"/> Not fulfilled<br><input type="checkbox"/> n.a. |

- |         |  |  |
|---------|--|--|
| 2.4.6.4 | <p>If appropriate, the following warning shall also be included</p> <p>The fastening of this visor is such that it will not be possible to remove it instantly from the line of sight with one hand should an emergency (such as headlamp glare or misting) occur.</p> | <input checked="" type="checkbox"/> fulfilled<br><input type="checkbox"/> Not fulfilled<br><input type="checkbox"/> n.a. |
| 2.4.6.5 | <p>If the visor is MIST RETARDANT approved it may be indicated</p>   | <input type="checkbox"/> fulfilled<br><input type="checkbox"/> Not fulfilled<br><input checked="" type="checkbox"/> n.a. |
| 2.4.6.6 | <p>Instructions regarding the detention of obsolescence</p>  | <input checked="" type="checkbox"/> fulfilled<br><input type="checkbox"/> Not fulfilled<br><input type="checkbox"/> n.a. |

**3 Other information**

Place of testing:	SGS CSTC Guangzhou, P.R. China
Date of testing:	20.04.2016

**4 Remarks:** ---



---

**List of modifications**

1	Correction of	Correct the material of shell from “ABS” to “fiber-glass” in Annex 1: Drawing of the Helmets
2	Modification of	n.a.
3	Addition of	Variants / Versions add “Carbon fiber shell version”
4	Deletion of	n.a.

# INFORMATION DOCUMENT

No.: R22-FF1300-02



**Jiangmen Pengcheng Helmets Co., Ltd.**

**TYPE: FF1300**

Protective Helmet with visor  
pursuant to

**Regulation No. 22**

UNIFORM PROVISIONS CONCERNING THE APPROVAL OF  
PROTECTIVE HELMETSS AND THEIR VISORS FOR DRIVERS AND  
PASSENGERS OF MOTORCYCLES AND MOPEDS

Signature of a responsible person:

A handwritten signature in black ink, appearing to be 'J. Pengcheng', written over a horizontal line.

Date: 24.03.2016

**Reason of extension:**

**Correction:** Correct the material of shell from "ABS" to "fiberglass" in Annex 1: Drawing of the Helmets

**Modification:** n.a.

**Addition:** Variants / Versions add "Carbon fiber shell version"

**Deletion:** n.a.





Type : FF1300  
 Manufacture : Jiangmen Pengcheng Helmets Co., Ltd.

Date:24.03.2016  
 Page 2 of 19

**0 GENERAL INFORMATION**

- 0.1 Make (trade name of manufacturer) : LS2, MHR, TAKAI
- 0.2 Type : FF1300
- 0.2.1 Commercial description(s) : FF1300, FF397
- 0.3 Variants / Versions : **1: Fiberglass shell version**  
**2: Carbon fiber shell version**
- 0.4 Name and address of manufacturer : Jiangmen Pengcheng Helmets Co., Ltd.  
Industrial Park East, Gonghe Town, Heshan City Guangdong Province, China
- 0.5 Name and address of assembly plant : Jiangmen Pengcheng Helmets Co., Ltd.  
Industrial Park East, Gonghe Town, Heshan City Guangdong Province, China
- 0.6 Name and address of manufacturer's authorized representative(if any) : n.a.
- 0.7 Location and method of affixing of the international approval mark : Marked in a label sewn on the retention system chin strap, see Annex 6

**1 TECHNICAL DESCRIPTION**

- 1.1 Description of the Helmets
  - 1.1.1 Type of Helmets : Full face
  - 1.1.2 Type of lower face cover : "P" protective
  - 1.1.3 Size (s) : XXS(51/52), XS(53/54), S(55/56), M(57/58), L(59/60), XL(61/62), XXL(63/64), XXXL(65/66)
  - 1.1.4 Drawing of the Helmets : see Annex 1
  - 1.1.5 Type(s) of visor to which may be equipped with this Helmets : FF-MHR-80
- 1.2 Description of the visor : Visor type: FF-MHR-80  
Approval No.: E1 22R 05300508
- 1.3 Description of the shell
  - 1.3.1 Material : **Fiberglass or Carbon fiber**
  - 1.3.2 Manufacture method : Bag pressure by molding
  - 1.3.3 Ventilation : see Annex 1
  - 1.3.4 Composition of the border join on the shell : PVC
  - 1.3.5 Drawing of the shell : see Annex 3
- 1.4 Description of protective padding
  - 1.4.1 Composition : Expanded polystyrene
  - 1.4.2 Density and weight :

Size (cm)	Shell size	Comfort padding thickness (Main) (mm)	Protective padding Density (Main + Top + Ear) (Kg/m <sup>3</sup> )	Protective padding Thickness (mm)	Protective padding Weight (Main + Top + Ear) (grams)
XXS(51/52)	S	16	45+24+50	32-35	70+15+60
XS(53/54)	S	12	45+24+50	32-35	70+15+60
S(55/56)	S	8	45+24+50	32-35	70+15+60
M(57/58)	M	12	45+24+70	32-35	93+15+70
L(59/60)	M	8	60+24+70	32-35	120+15+70
XL(61/62)	L	12	65+24+70	32-35	158+15+80
XXL(63/64)	L	8	65+24+70	32-35	158+15+80
XXXL(65/66)	L	7	65+24+70	32-35	158+15+80

- 1.4.3 Drawing of the protective padding : see Annex 4



Type : FF1300  
 Manufacture : Jiangmen Pengcheng Helmets Co., Ltd.

Date:24.03.2016

Page 3 of 19

- 1.5 Description of comfort padding
  - 1.5.1 Composition of Comfort padding : Compound sponge
  - Comfort tissue : Nylon
  - Protection of the back of the nape : Sponge, textile and leather
  - Lateral packing : EPS and compound sponge
  - Lower face cover : EPS and PU
  - 1.5.2 Drawing of the comfort padding : see Annex 5
  
- 1.6 Description of the retention system
  - 1.6.1 Chin strap
    - Material : Nylon
    - Width : 22 mm or 25 mm
  - 1.6.2 Retention system : Type 1: Double-D ring with 25mm Chin strap  
 Type 2: No.15 quick release mechanism with 22mm Chin strap  
 Type 3: No.17 quick release mechanism with 22mm Chin strap
  - 1.6.3 Comfort padding of the retention system
    - Composition : Leather and textile
    - Thickness : 3 mm
  - 1.6.4 Anchorage system to the shell : By means of a metallic piece fixed to the shell by rivets
  - 1.6.5 Drawing of the retention system : see Annex 6
  
- 1.7 Other Characteristics
  - 1.7.1 Markings
    - Make : Rear part of the shell
    - Weight : Rear part of the shell
    - Size : Rear part of the shell
  - 1.7.2 Indelible marking
    - How it is made : Sewing
    - Position : On the chin strap
  
- 1.8 Accessories
  - 1.8.1 Peak : n.a.
  - 1.8.2 Information for wearer
    - 1.8.2.1 Text : see Annex 7
    - 1.8.2.2 Position : Hang on chin strap



Type : FF1300  
 Manufacture : Jiangmen Pengcheng Helmets Co., Ltd.

Date:24.03.2016

Page 4 of 19

---

**ANNEXS**

<b>Annex 1</b>	<b>Drawing of the Helmets</b>	<b>24.03.2016</b>
Annex 2	Drawing of the sun shade	19.07.2015
<b>Annex 3</b>	<b>Drawing of the shell</b>	
	<b>Shell type: Small</b>	<b>24.03.2016</b>
	<b>Shell type: Medium</b>	<b>24.03.2016</b>
	<b>Shell type: Large</b>	<b>24.03.2016</b>
Annex 4	Drawing of the protective padding	19.07.2015
Annex 5	Drawing of the comfort padding	19.07.2015
Annex 6	Drawing of the retention system	19.07.2015
Annex 7	Information for wearer	19.07.2015

Annex 1: Drawing of the Helmets

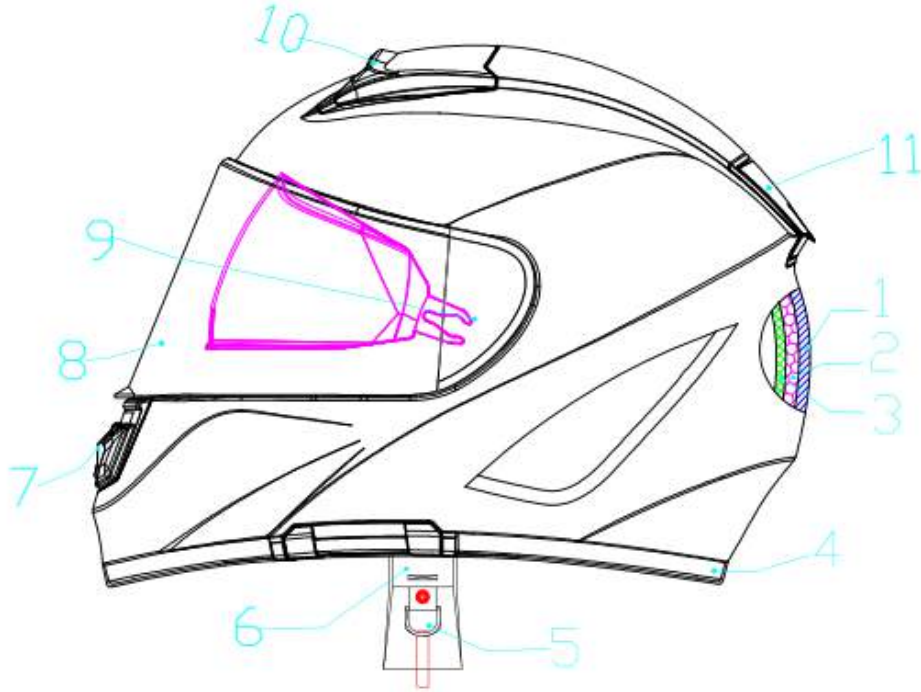

序号 number	名称 name	单位 unit	数量 piece	材料 material
1	壳体 Outer shell	↑ piece	1	fiberglass or Carbon fiber
2	泡沫 protective padding	↑ piece	5	eps
3	内衬 comfort padding	套 set	1	nylon
4	下胶边 rubber ring	条 unit	1	pvc
5	快速扣/D型平面铁环扣 buckle/Double"D"ring	套 set	1	a3/ stainless steel
6	下巴带 chin strap	条 unit	2	nylon
7	下巴风窗 mouth vent	套 set	1	abs
8	镜片 visor	↑ piece	1	pc
9	底座 Ratchet system	套 set	2	pom
10	顶前风窗 top vent	↑ piece	1	abs
11	后风窗 back vent	↑ piece	1	abs

MODEL	FF1300							
SIZE	XXXL	XXL	XL	L	M	S	XS	XXS
CM	66-65	64-63	62-61	60-59	58-57	56-55	54-53	52-51
技术要求 technical requirement	1.The surface of the outshell should be smooth and bright no mottle, pinhold,bulb,drop lack of oil ,disdosuie of basic color. 2. Every spare parts should be fixed correctly , and not be loose,misssed.							



Type : FF1300  
 Manufacture : Jiangmen Pengcheng Helmets Co., Ltd.

Date: 24.03.2016  
 Page 6 of 19

Annex 2: Drawing of the sun shade

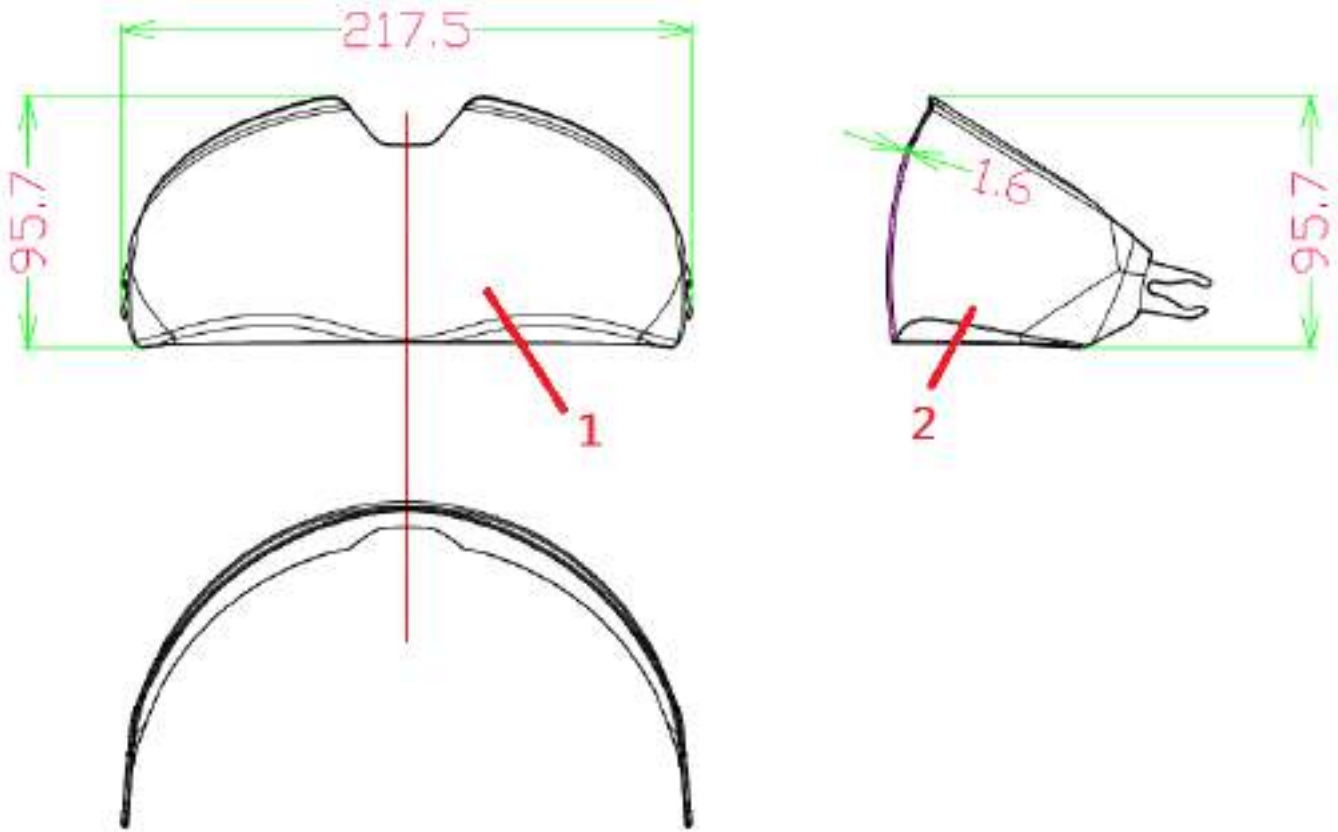

Unit: mm

Number	Name	Parameter	Number	Name	Parameter
1	Sun shade	PC	2	Sun shade warning	DAY USE ONLY
<b>Description</b>	FF1300 sun shade		<b>Code No.:</b>	FF1300.1	
<b>Manufacturer:</b>	Jiangmen Pengcheng Helmets Co., Ltd.				
<b>Address:</b>	Industrial Park East, Gonghe Town, Heshan City Guangdong Province, China				
<b>Drawn by:</b>	Rongfu Zhou	<b>Checked by:</b>	Rongfu Zhou	<b>Approved by:</b>	Yun Wang
<b>Date:</b>	26.06.2015	<b>Date:</b>	02.07.2015	<b>Date:</b>	19.07.2015



Type : FF1300  
 Manufacture : Jiangmen Pengcheng Helmets Co., Ltd.

Date:24.03.2016  
 Page 7 of 19

Annex 3: Drawing of the shell

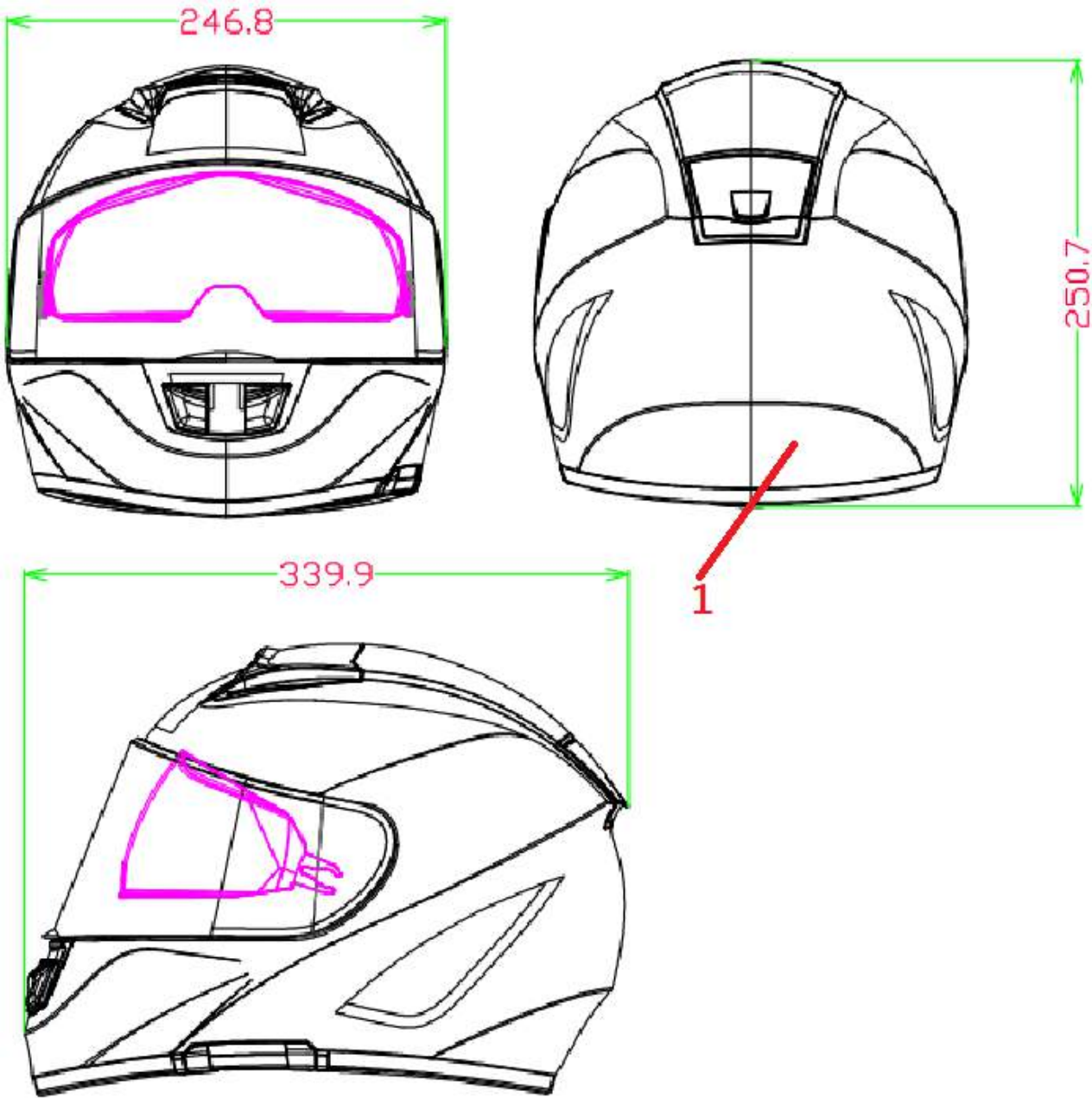

Unit: mm

Number	Name	Parameter	Number	Name	Parameter
1	Shell	Fiberglass or Carbon fiber			
<b>Description</b>	FF1300 Small Shell		<b>Code No.:</b>	FF1300.2.1	
<b>Manufacturer:</b>	Jiangmen Pengcheng Helmets Co., Ltd.				
<b>Address:</b>	Industrial Park East, Gonghe Town, Heshan City Guangdong Province, China				
<b>Drawn by:</b>	Rongfu Zhou	<b>Checked by:</b>	Rongfu Zhou	<b>Approved by:</b>	Yun Wang
<b>Date:</b>	24.03.2016	<b>Date:</b>	24.03.2016	<b>Date:</b>	24.03.2016



**INFORMATION DOCUMENT**

R22-FF1300-02



Type : FF1300  
 Manufacture : Jiangmen Pengcheng Helmets Co., Ltd.

Date: 24.03.2016  
 Page 8 of 19

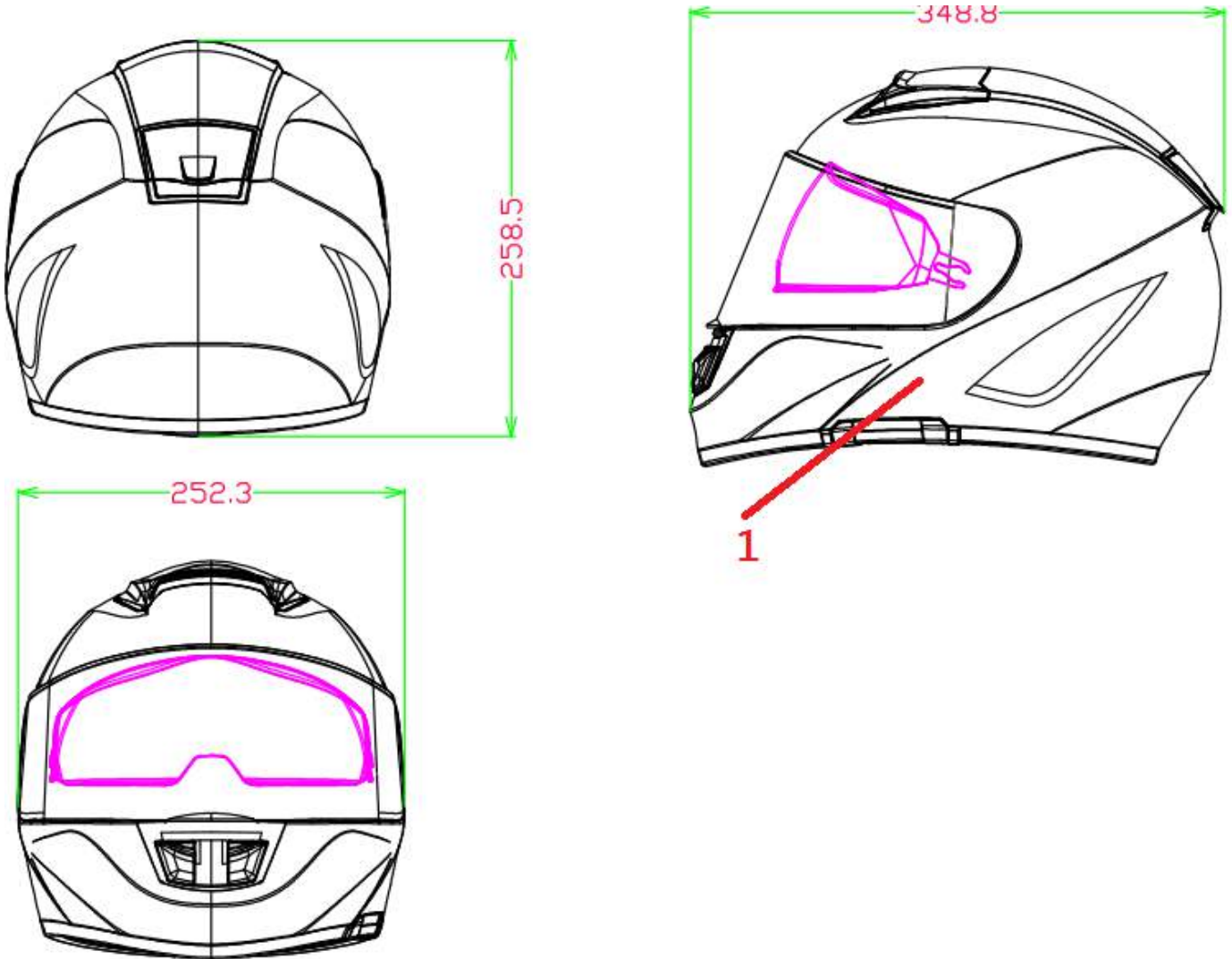

Unit: mm

Number	Name	Parameter	Number	Name	Parameter
1	Shell	Fiberglass or Carbon fiber			
<b>Description</b>	FF1300 Medium Shell		<b>Code No.:</b>	FF1300.2.2	
<b>Manufacturer:</b>	Jiangmen Pengcheng Helmets Co., Ltd.				
<b>Address:</b>	Industrial Park East, Gonghe Town, Heshan City Guangdong Province, China				
<b>Drawn by:</b>	Rongfu Zhou	<b>Checked by:</b>	Rongfu Zhou	<b>Approved by:</b>	Yun Wang
<b>Date:</b>	24.03.2016	<b>Date:</b>	24.03.2016	<b>Date:</b>	24.03.2016

**INFORMATION DOCUMENT**

R22-FF1300-02



Type : FF1300  
 Manufacture : Jiangmen Pengcheng Helmets Co., Ltd.

Date: 24.03.2016  
 Page 9 of 19

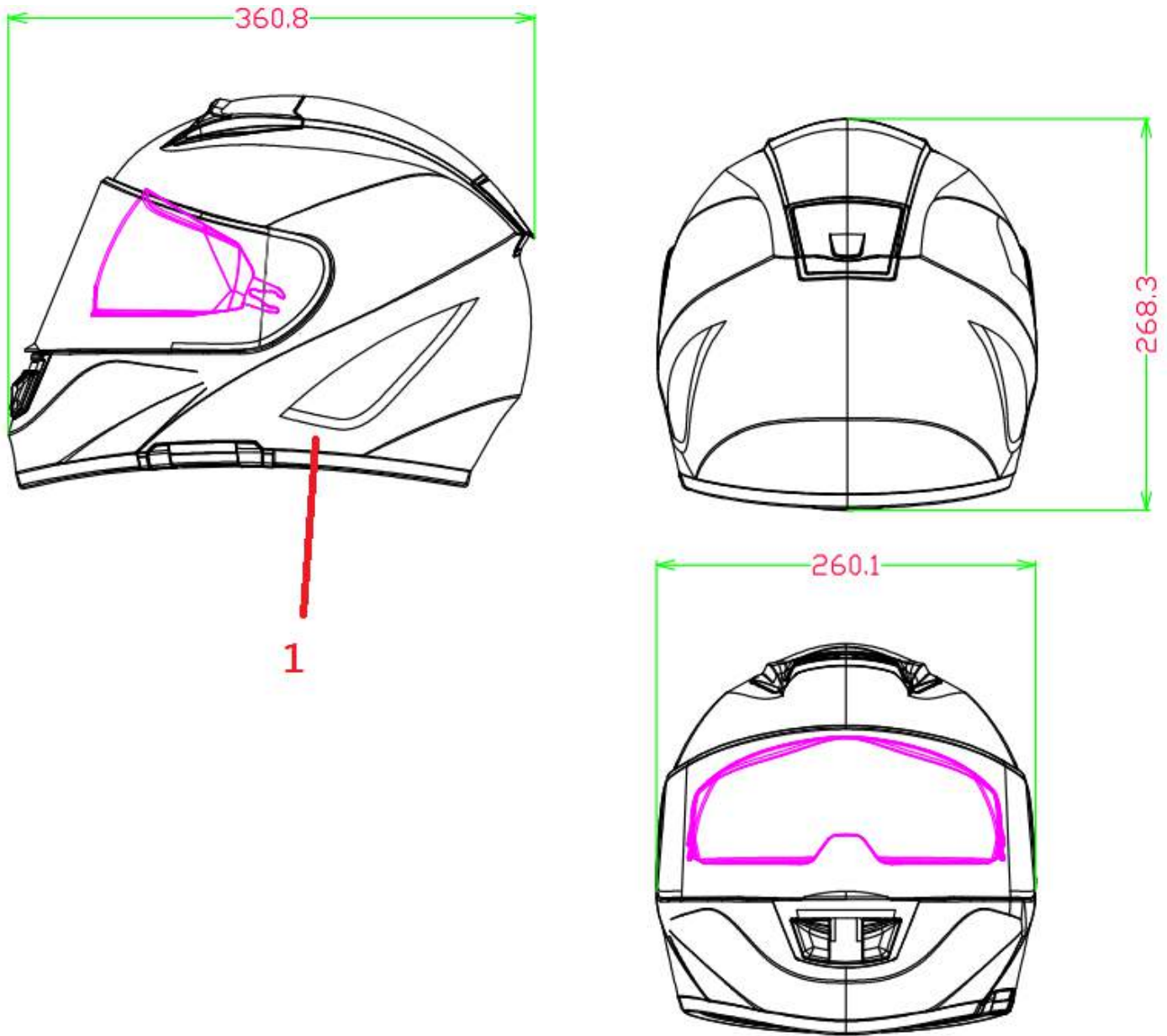

Unit: mm

Number	Name	Parameter	Number	Name	Parameter
1	Shell	Fiberglass or Carbon fiber			
<b>Description</b>	FF1300 Large Shell		<b>Code No.:</b>	FF1300.2.3	
<b>Manufacturer:</b>	Jiangmen Pengcheng Helmets Co., Ltd.				
<b>Address:</b>	Industrial Park East, Gonghe Town, Heshan City Guangdong Province, China				
<b>Drawn by:</b>	Rongfu Zhou	<b>Checked by:</b>	Rongfu Zhou	<b>Approved by:</b>	Yun Wang
<b>Date:</b>	24.03.2016	<b>Date:</b>	24.03.2016	<b>Date:</b>	24.03.2016





Type : FF1300  
 Manufacture : Jiangmen Pengcheng Helmets Co., Ltd.

Date: 24.03.2016  
 Page 10 of 19

Annex 4: Drawing of the protective padding

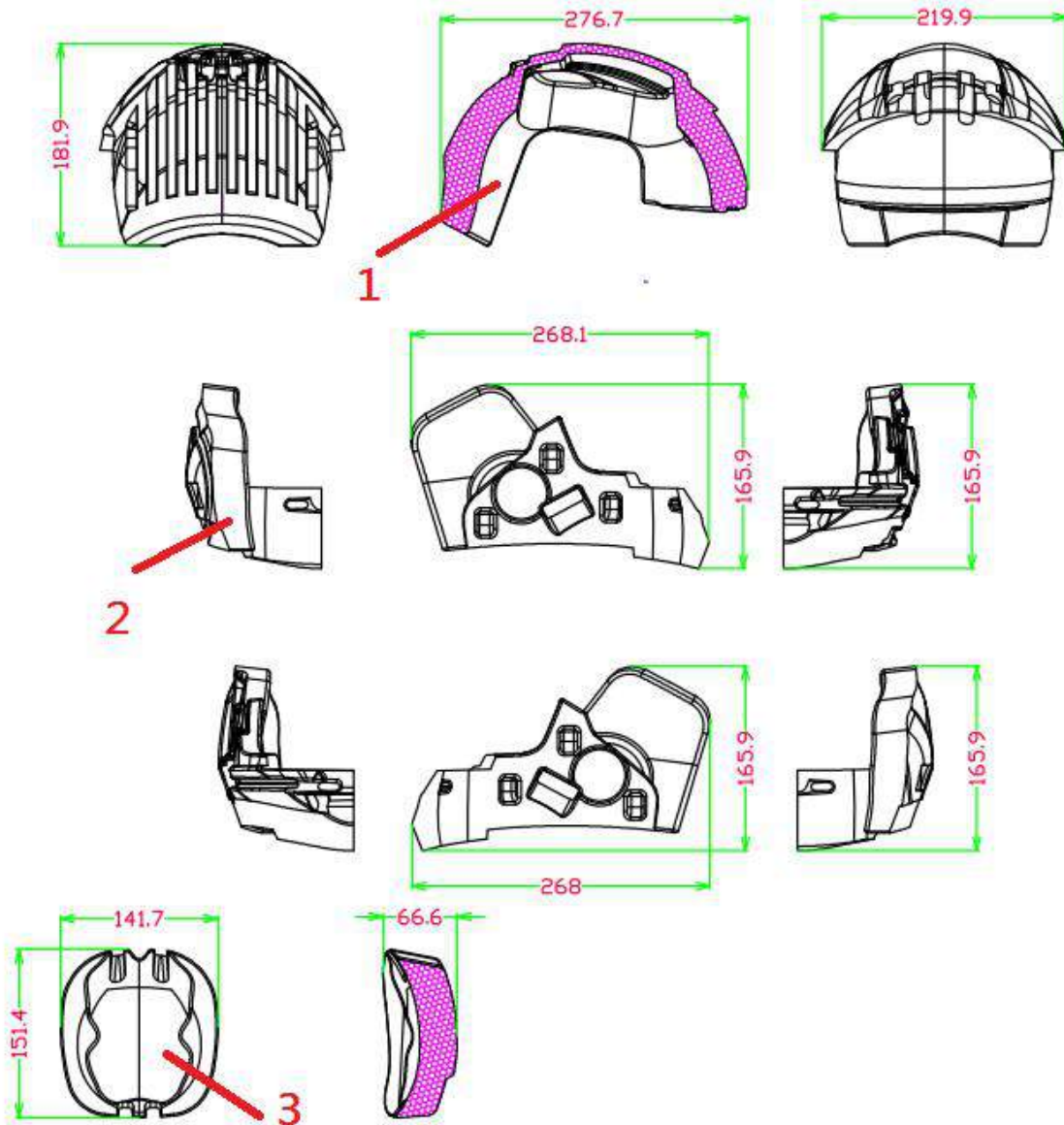

Unit: mm

Number	Name	Parameter	Number	Name	Parameter
1	Main Protective padding	EPS	3	Top inner protective padding	EPS
2	Ear Protective padding	EPS			
<b>Description</b>	FF1300 Small Protective padding		<b>Code No.:</b>	FF1300.3.1	
<b>Manufacturer:</b>	Jiangmen Pengcheng Helmets Co., Ltd.				
<b>Address:</b>	Industrial Park East, Gonghe Town, Heshan City Guangdong Province, China				
<b>Drawn by:</b>	Rongfu Zhou	<b>Checked by:</b>	Rongfu Zhou	<b>Approved by:</b>	Yun Wang
<b>Date:</b>	26.06.2015	<b>Date:</b>	02.07.2015	<b>Date:</b>	19.07.2015

INFORMATION DOCUMENT

R22-FF1300-02



Type : FF1300  
 Manufacture : Jiangmen Pengcheng Helmets Co., Ltd.

Date: 24.03.2016  
 Page 11 of 19

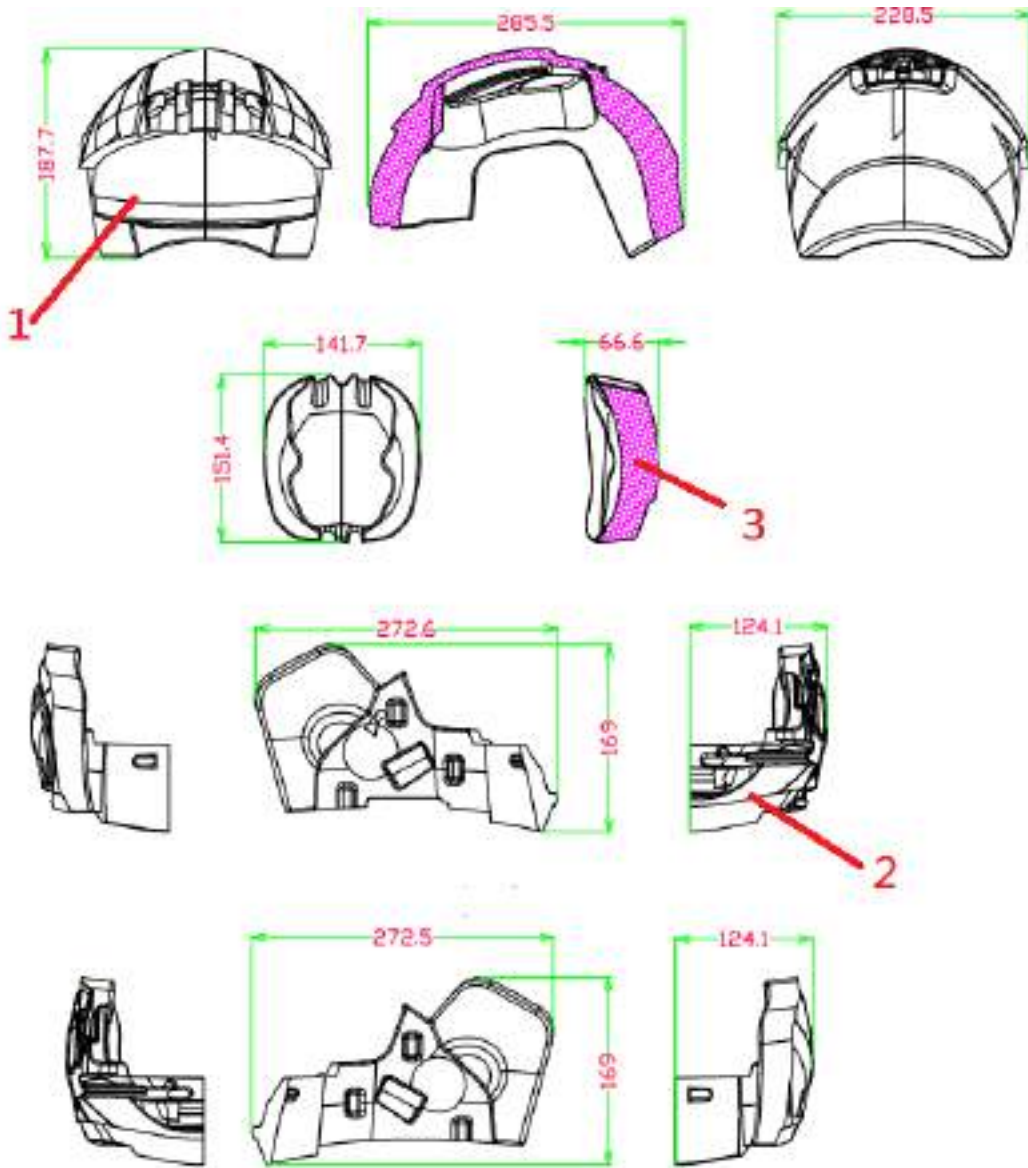

Unit: mm

Number	Name	Parameter	Number	Name	Parameter
1	Main Protective padding	EPS	3	Top inner protective padding	EPS
2	Ear Protective padding	EPS			
<b>Description</b>	FF1300 Medium Protective padding		<b>Code No.:</b>	FF1300.3.2	
<b>Manufacturer:</b>	Jiangmen Pengcheng Helmets Co., Ltd.				
<b>Address:</b>	Industrial Park East, Gonghe Town, Heshan City Guangdong Province, China				
<b>Drawn by:</b>	Rongfu Zhou	<b>Checked by:</b>	Rongfu Zhou	<b>Approved by:</b>	Yun Wang
<b>Date:</b>	26.06.2015	<b>Date:</b>	02.07.2015	<b>Date:</b>	19.07.2015

INFORMATION DOCUMENT

R22-FF1300-02



Type : FF1300  
 Manufacture : Jiangmen Pengcheng Helmets Co., Ltd.

Date: 24.03.2016  
 Page 12 of 19

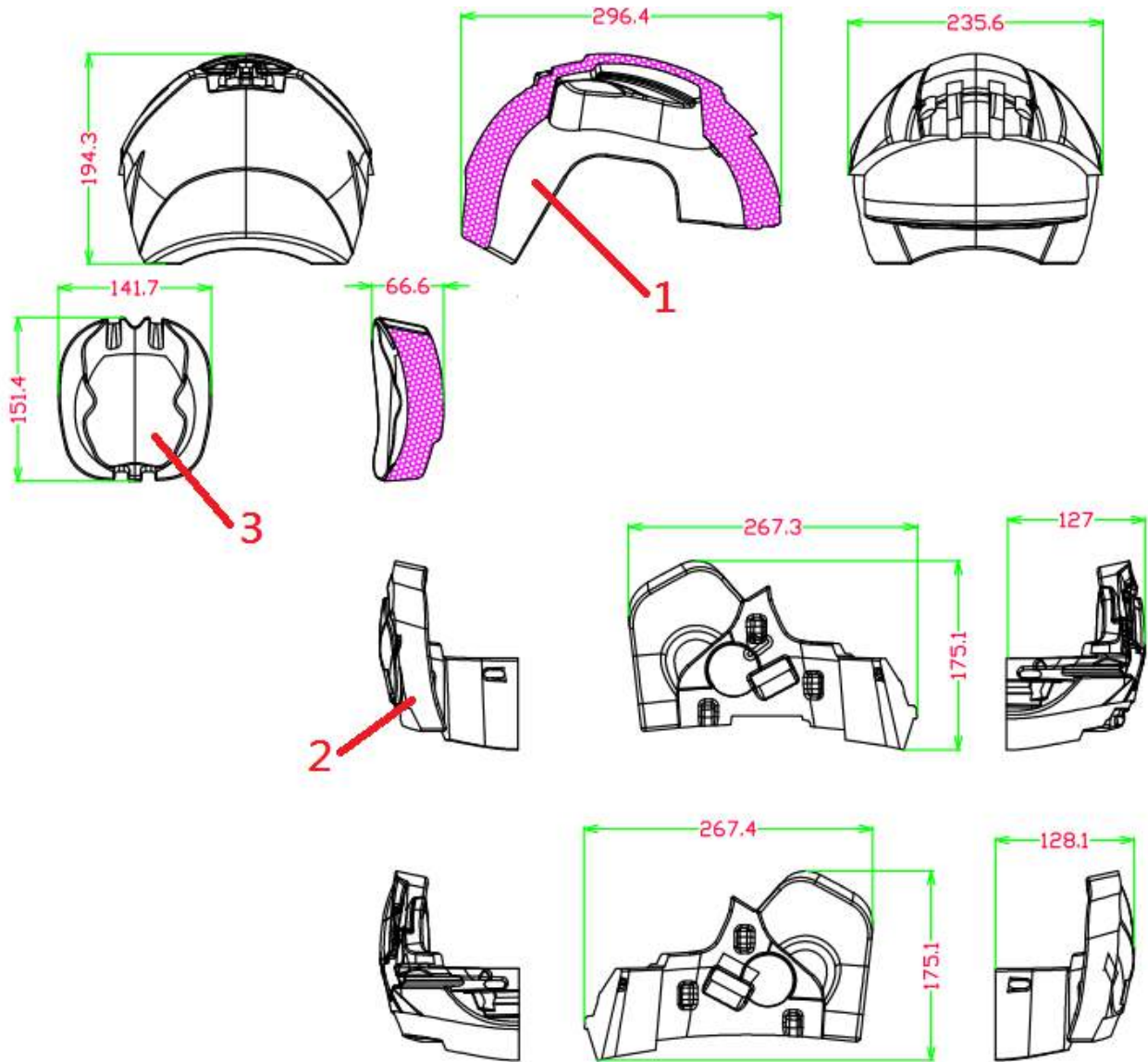

Unit: mm

Number	Name	Parameter	Number	Name	Parameter
1	Main Protective padding	EPS	3	Top inner protective padding	EPS
2	Ear Protective padding	EPS			
<b>Description</b>	FF1300 Large Protective padding		<b>Code No.:</b>	FF1300.3.3	
<b>Manufacturer:</b>	Jiangmen Pengcheng Helmets Co., Ltd.				
<b>Address:</b>	Industrial Park East, Gonghe Town, Heshan City Guangdong Province, China				
<b>Drawn by:</b>	Rongfu Zhou	<b>Checked by:</b>	Rongfu Zhou	<b>Approved by:</b>	Yun Wang
<b>Date:</b>	26.06.2015	<b>Date:</b>	02.07.2015	<b>Date:</b>	19.07.2015



Type : FF1300  
 Manufacture : Jiangmen Pengcheng Helmets Co., Ltd.

Date: 24.03.2016  
 Page 13 of 19

Annex 5: Drawing of the comfort padding

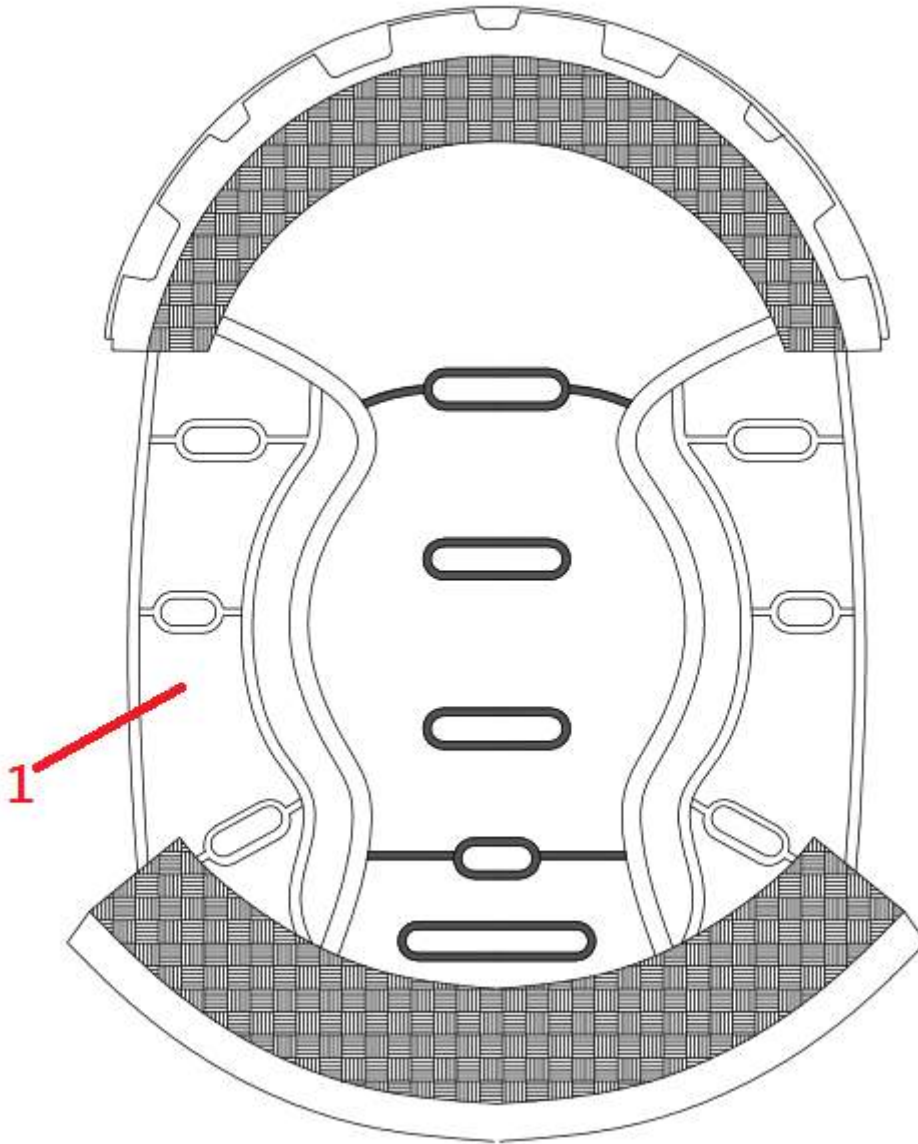

Number	Name	Material	Number	Name	Material
1	Comfort padding	Compound sponge + Nylon Cloth			
<b>Description</b>	FF1300 Comfort padding		<b>Code No.:</b>	FF1300.4	
<b>Manufacturer:</b>	Jiangmen Pengcheng Helmets Co., Ltd.				
<b>Address:</b>	Industrial Park East, Gonghe Town, Heshan City Guangdong Province, China				
<b>Drawn by:</b>	Rongfu Zhou	<b>Checked by:</b>	Rongfu Zhou	<b>Approved by:</b>	Yun Wang
<b>Date:</b>	26.06.2015	<b>Date:</b>	02.07.2015	<b>Date:</b>	19.07.2015



Type : FF1300  
 Manufacture : Jiangmen Pengcheng Helmets Co., Ltd.

Date: 24.03.2016  
 Page 14 of 19

Annex 6: Drawing of the retention system

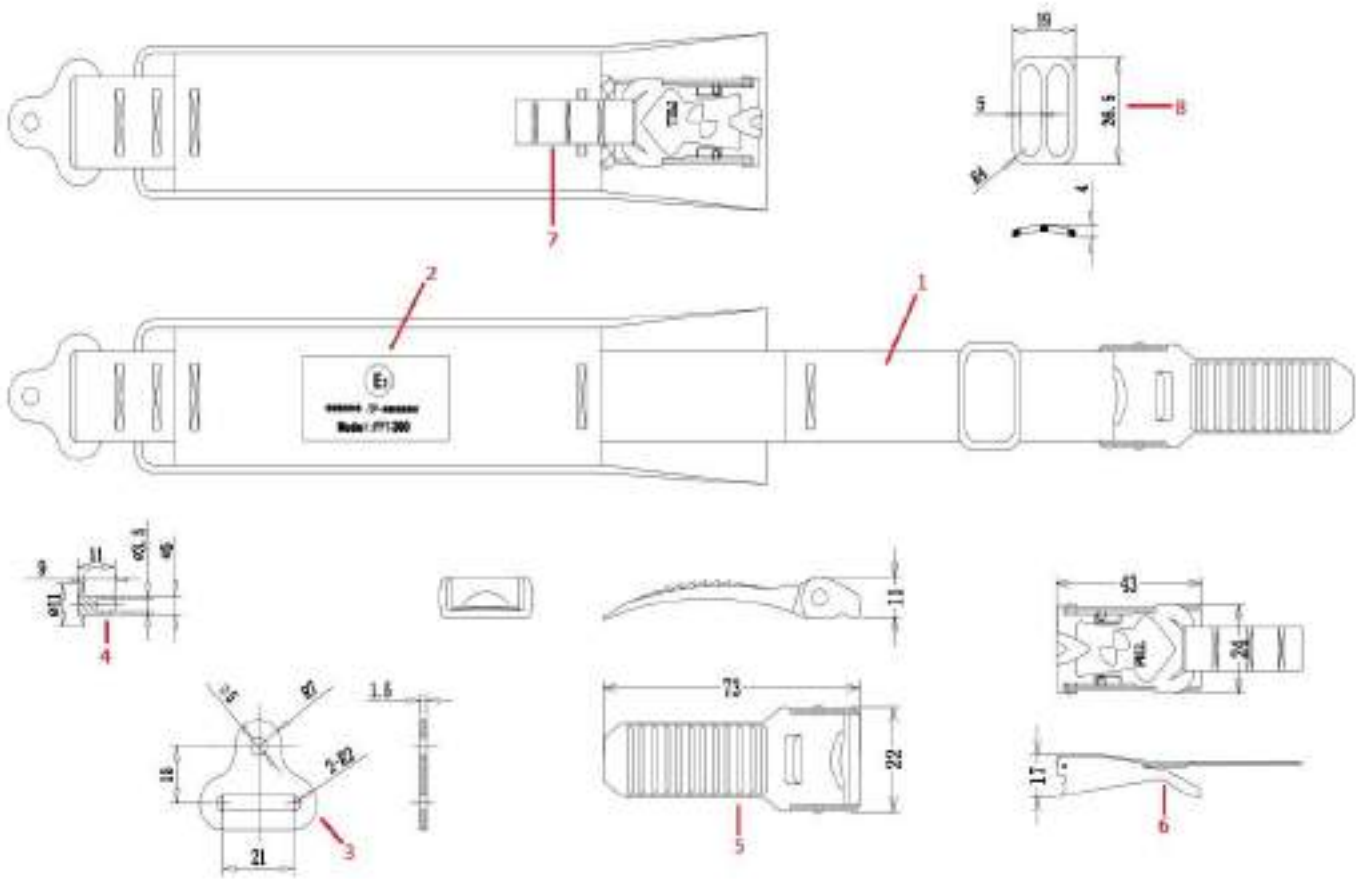

Unit: mm

Number	Name	Material	Number	Name	Material
1	Chin strap	Nylon	5	Slider	Polycarbonate + Steel
2	ECE Marking	Cloth	6	Quick release buckle	Polycarbonate + Steel
3	Hinge	Steel	7	Red small strap	Nylon
3	Rivet	Steel	8	"B" Ring	Nylon
<b>Description</b>	FF1300 Retention system (15 Buckle)		<b>Code No.:</b>	FF1300.5.1	
<b>Manufacturer:</b>	Jiangmen Pengcheng Helmets Co., Ltd.				
<b>Address:</b>	Industrial Park East, Gonghe Town, Heshan City Guangdong Province, China				
<b>Drawn by:</b>	Rongfu Zhou	<b>Checked by:</b>	Rongfu Zhou	<b>Approved by:</b>	Yun Wang
<b>Date:</b>	26.07.2015	<b>Date:</b>	02.07.2015	<b>Date:</b>	19.07.2015



**INFORMATION DOCUMENT**

R22-FF1300-02



Type : FF1300  
 Manufacture : Jiangmen Pengcheng Helmets Co., Ltd.

Date: 24.03.2016  
 Page 15 of 19

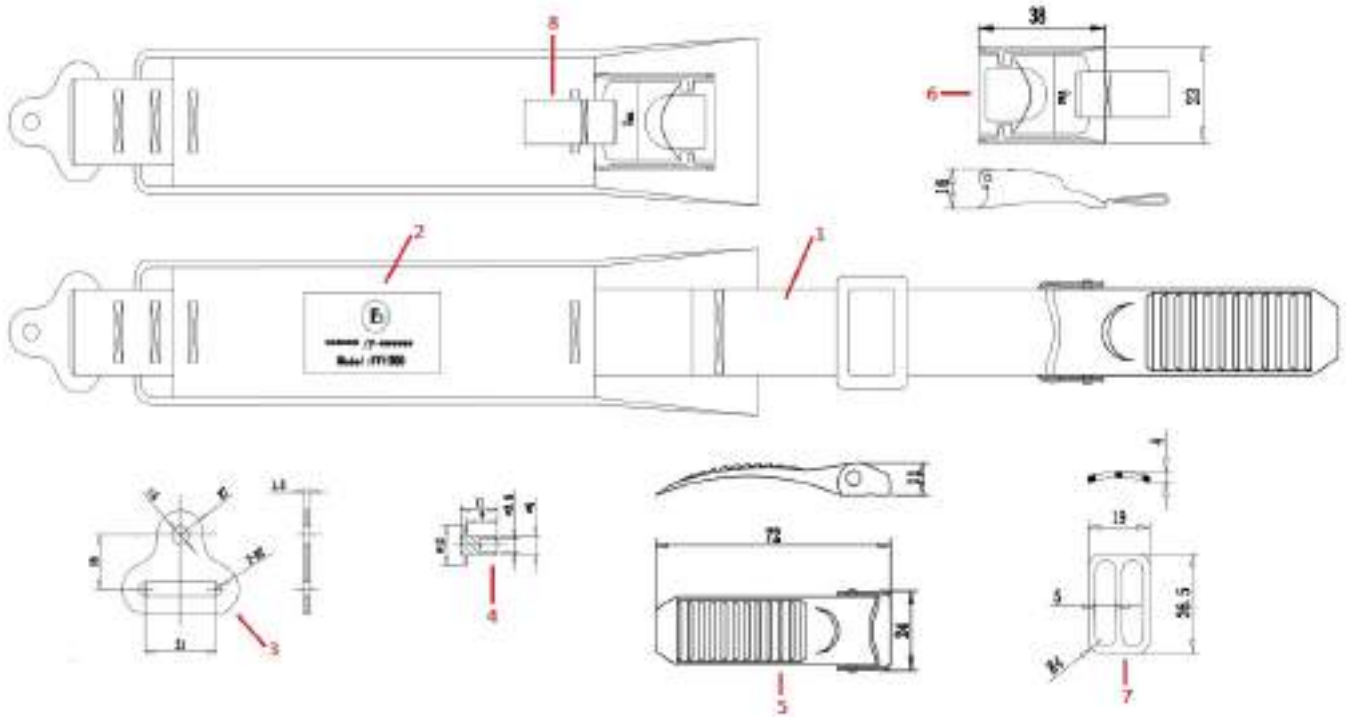

Unit: mm

Number	Name	Material	Number	Name	Material
1	Chin strap	Nylon	5	Slider	Polycarbonate + Steel
2	ECE Marking	Cloth	6	Quick release buckle	Polycarbonate + Steel
3	Hinge	Steel	7	Red small strap	Nylon
3	Rivet	Steel	8	"B" Ring	Nylon
<b>Description</b>	FF1300 Retention system (17 Buckle)		<b>Code No.:</b>	FF1300.5.2	
<b>Manufacturer:</b>	Jiangmen Pengcheng Helmets Co., Ltd.				
<b>Address:</b>	Industrial Park East, Gonghe Town, Heshan City Guangdong Province, China				
<b>Drawn by:</b>	Rongfu Zhou	<b>Checked by:</b>	Rongfu Zhou	<b>Approved by:</b>	Yun Wang
<b>Date:</b>	26.06.2015	<b>Date:</b>	02.07.2015	<b>Date:</b>	19.07.2015

**INFORMATION DOCUMENT**

R22-FF1300-02



Type : FF1300  
 Manufacture : Jiangmen Pengcheng Helmets Co., Ltd.

Date: 24.03.2016  
 Page 16 of 19

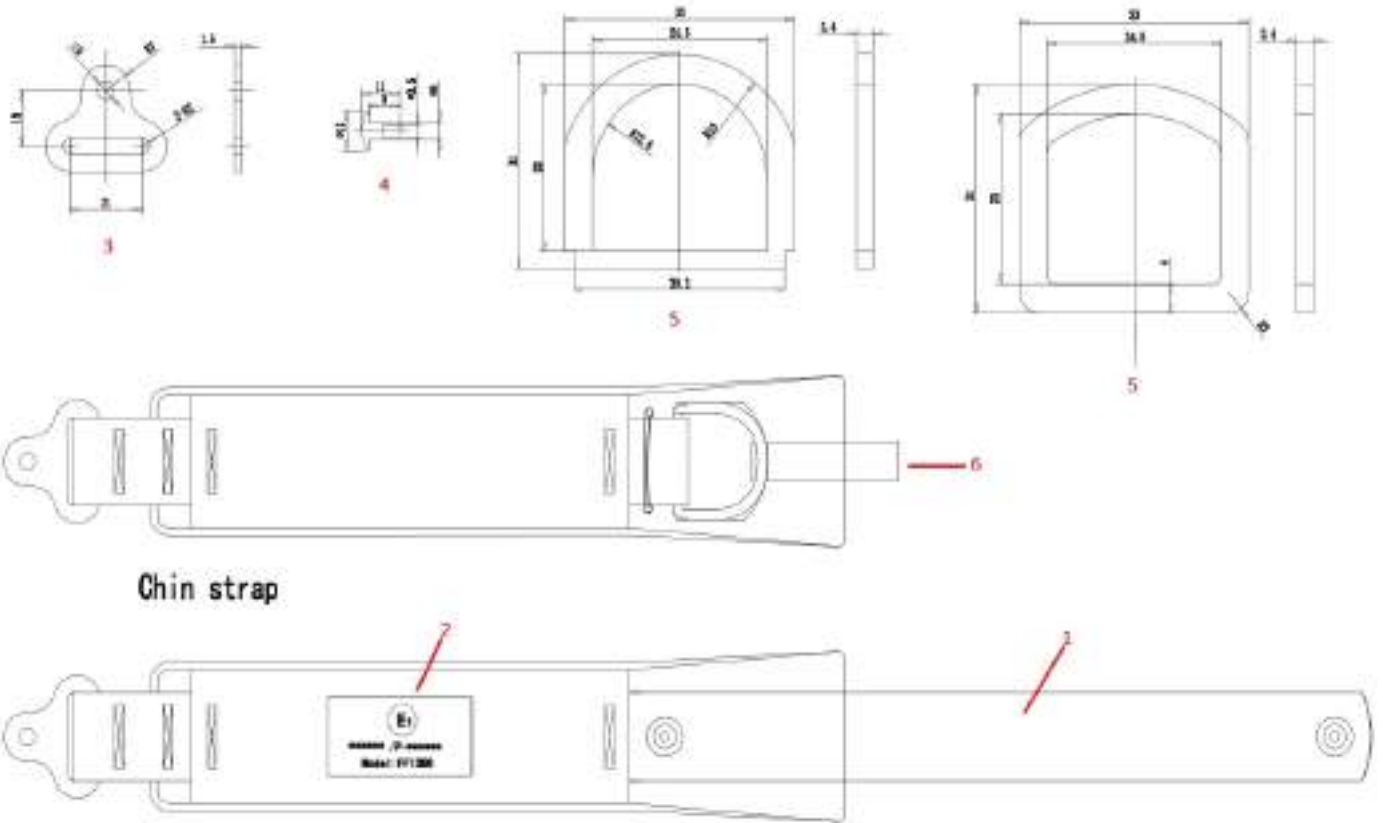

Number	Name	Material	Number	Name	Material
1	Chin strap	Nylon	5	"D" Ring	Steel
2	ECE Marking	Cloth	6	Red small strap	Nylon
3	Hinge	Steel			
4	Rivet	Steel			
<b>Description</b>	FF324 Retention system (Double "D" Ring)		<b>Code No.:</b>	FF324.5.3	
<b>Manufacturer:</b>	Jiangmen Pengcheng Helmets Co., Ltd.				
<b>Address:</b>	Industrial Park East, Gonghe Town, Heshan City Guangdong Province, China				
<b>Drawn by:</b>	Rongfu Zhou	<b>Checked by:</b>	Rongfu Zhou	<b>Approved by:</b>	Yun Wang
<b>Date:</b>	26.05.2015	<b>Date:</b>	02.06.2015	<b>Date:</b>	02.06.2015

**Annex 7: Information for wearer**

Congratulations on purchasing your new helmet. Please read these instructions carefully before use. They contain valuable information to help you obtain the most protection from your helmet and to ensure a longer life for your helmet. All our products come from the most advanced research in terms of active security and design. The very high level for aerodynamicism and comfort will get you the best performance all along the road. Whatever can do your choice (cruiser, touret, racing, one of the helmets from the LSZ range) is the best solution for your active profession.

1. Read these instructions thoroughly before using your helmet for the first time and store them safely for future reference.
2. A helmet like all products may wear out over time, depending upon its use and the amount of care that is given. Please check your helmet every time before use for damage and do not use a damaged helmet. The most known standards of homologation recommend a helmet life of five years. LSZ agrees with this recommendation even though your helmet does not show any signs of malfunction, visible damage or defect. We strongly recommend you replace your helmet five years after the original date of purchase. See also "ONE IMPACT RULE" of item 3 in this manual, which says clearly "helmet is designed to help absorb one impact".
3. If you have any questions or comments concerning this helmet, please contact your nearest LSZ dealer or agent. Note that these specifications are subject to change without notice, as we continuously strive to improve our products.

**HOW TO CHOOSE A HELMET AND WEAR IT CORRECTLY**

No helmet can protect the wearer against all foreseeable high speed and low speed impact, however, for maximum head protection the helmet must be of proper fit and the retention system must be securely fastened under the chin. Failure to have proper fit and to securely fasten the helmet is dangerous as the helmet could come off in an accident resulting in severe head injury or death.

**1 To determinate proper fit.**

- 1.1. Measure your head size. Wrap a tape measure horizontally around your head at the height of about 2,5 cm above your eyebrows. This will establish the largest measurement around your head.
- 1.2. Select the helmet that is the closest match to your head size. If your head size should fit between two helmet sizes, try on the smaller one first.

**2 Try the helmet on**

- 2.1. Expand the helmet opening by the straps, and slide your head into the helmet. Pull the chin straps only, not the chin straps cover, pulling on the covers may rip them. If the helmet is not tight, it is too big for you. If you are unfamiliar with helmets you may be reluctant to pull down the helmet which should feel tight. Even if you feel it is difficult to put it on, please use the smallest helmet possible.

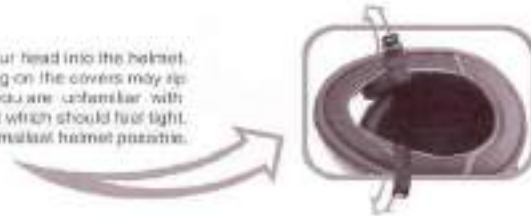

**3 Check for a proper fit. With the helmet, go through the following checklist to determine whether the helmet is the correct size.**

- 3.1. Make sure the inner lining fits snugly all around your head.
- 3.2. Make sure the top pad presses closely to the top of your head.
- 3.3. Check whether the cheek pads are in contact with your cheeks.
- 3.4. Make sure there is no space between inner lining and brow where you could insert your finger.
- 3.5. Now, take hold of the helmet with a hand on each side. Without moving your head, try to move the helmet up and down, and side to side. You should feel the skin of your head and face being pulled as you try to move the helmet. If you can move the helmet around easily, it is too big. Try a smaller size.



**4 Check the retention system and go through the following steps.**

- 4.1. Fasten the chinstrap as tight as possible without causing you pain (see diagram 2). There must be no slack in the strap and it must be tight up against your chin.
- 4.2. With the chinstrap secured, put your hands flat on the back of the helmet and try to push the helmet off by rotating forward.
- 4.3. Next, put your hands on the front of the helmet above your forehead (or on the cringuard) and try to push the helmet off by rotating it toward the rear.
- 4.4. If the helmet starts to come off in either direction, do not use the helmet, either the helmet is too large for you or the chin strap is not tightened enough.



Tightening the chinstrap correctly is extremely important. Try to pull down on the chinstrap with the tips of your fingers if the strap is not against your chin or loosens, you have not properly put the strap through the D rings. Start again (see diagram 2). If your chinstrap is loose, the shock of an impact may knock your helmet off, leaving your head completely unprotected. Do not use a helmet that can be rolled off the hood with the chinstrap fastened, since it may come off in an accident, resulting in death or serious personal injuries.



**ENGLISH**



**D RING:** To securely fasten the D ring retention system, thread the end of the chinstrap through the D rings only as shown in diagram 2 and put it tight against your throat. Clip the chin strap and hook on the D ring as shown in diagram 2 to secure the loose end of the chin strap after it's securely fastening the chin strap. The only function of the chinstrap end hook fitted on the end of the chinstrap is to avoid flutering of the end part of the chinstrap.

**Quick-release retention system:** To fasten the strap, push the metal tongue firmly into the buckle until it locks with a click. Pull the strap tight and pass the end of the strap through the strap ring or ladder to secure it. To release the strap, press the two catches inward (or slide the catches down).

## SAFETY RECOMMENDATIONS

### 1

**No helmet can protect wearer against all foreseeable high speed and low speed impacts.**  
 However, for maximum head protection, the helmet must be of proper fit and retention system must be securely fastened under the chin. The helmet should allow peripheral vision when secure on your head. If your helmet is too large, it may slip or move on your head while riding which may make it possible for your helmet to come off in an accident or to obstruct your vision while riding. In the first case, your helmet will not protect your head in an accident, which can result in serious personal injury or death and in the second case, if you cannot see you may have an accident.

### 2

**Use only a helmet that fits snugly all around your head, and fasten the chinstrap securely under your chin.**  
 Expand the helmet opening with your hands, and slide your head into the helmet. Please check whether the helmet fits properly according to the checklist (paragraph 3, page 3). Pull the chinstraps only, not the chinstraps covers. Pulling on the covers may rip them. If the helmet is not tight, it is too big for you. To securely fasten the D ring retention system, thread the end of the chinstrap through the D rings only as shown, and pull it tight up against your throat. In the case of quick-release retention system, refer to upper paragraph. If your chinstrap is loose, the shock of an impact may knock your helmet off leaving your head completely unprotected resulting in serious personal injury or death.

### 3

**Helmets are designed to help absorb ONE impact. After your helmet has protected you from an impact, you must get a new one.**  
 Your helmet is designed to distribute the force incurred during an impact over a wide area. Even if your helmet looks undamaged externally its useful life is finished after one impact during riding, for example, a capsule or accident where you and your helmet hit the ground or some object. In an impact, the helmet's impact absorbing liner becomes compacted. Once this has happened, the helmet no longer has the ability to absorb further impacts. Your helmet may look the same, but it will not provide protection in an accident. If you have any doubts, for example, if you drop your helmet or if it is hit by something, and you are not sure if this one-impact rule applies, consult your LS2 dealer before you use the helmet again.



### 4

**Clean your helmet carefully.**  
 Never use hot or salt water, benzene, gasoline, glass cleaner or other solvents. Your helmet could be seriously damaged by these substances without showing any apparent visible damage. A helmet damaged or weakened by a cleaning agent may not provide head protection in an accident resulting in serious personal injury or death. The correct way to clean a helmet is to mix 3 or 6 drops of mild soap in a quart of warm water. Dampen a soft cloth with this solution and wipe the helmet clean. Rinse with a wet cloth.

### 5

**Never modify your helmet.**  
 It is very dangerous to drill holes or cut the shell and/or the shock absorber liner. Modifications can seriously weaken the helmet. Modifying the retention system weakens it, and it may snap in an impact, removing parts such as the mouth guard or rubber face trim can expose edges, which may injure you in an accident. Always use approved LS2 parts when replacing shields, screws, or any other parts. A weakened helmet will not provide protection.

### 6

**Don't mistreat your helmet.**  
 Never ride with the helmet hanging from the helmet holder, and don't hang the helmet from angled supports like a mirror. Don't sit on your helmet or throw it around. You should not expose the liner of your helmet to strong sunlight and excessive heat such as near heaters or where temperatures exceed 50° C (122° F). Avoid the spray of insect repellent chemicals (such as naphthalene) near the helmet. Mistreating your helmet will damage the shell and impact absorbing liner and reduce the helmet's ability to protect you in an accident.

### 7

- Always check your helmet before riding off.**
1. Check the shield and visor screws, and retighten them if necessary.
  2. Check for cracks in the helmet. Strong acid (for example, battery acid) can damage the shield base. If you find cracks or damage, stop using the helmet immediately.
  3. Plastic components may start to wear out about 5 years after manufacture. If you find deterioration in any part of a component, either replace that component or get a new helmet. If these parts come loose and / or fall off while you are riding, your vision may be blocked which could cause an accident resulting in serious personal injury or death.
  4. Check the security of the retention system
  5. Make sure that the center pad (or comfort liner) and the cheek pads are attached before you use the helmet.

ENGLISH





Type : FF1300  
 Manufacture : Jiangmen Pengcheng Helmets Co., Ltd.

Date: 24.03.2016  
 Page 19 of 19

**8**

**Maintain your helmet shield in good condition.**

If your shield becomes too scratched or uncleanable, replace it with a new one. Impaired visibility causes accidents. Clean your shield with mild soapy water, rinse well with clean water, and dry with a soft cloth. Never use benzene, gasoline, glass cleaner or any other solvents. Do not attach stickers or adhesive tape to the shield, as this will weaken the hard coating. This can damage the shield. Do not drive with a dim or blurred face shield. Impaired vision can cause an accident resulting in serious personal injury or death.

**9**

**Do not repaint the helmet.**

We do not recommend you repaint the helmet, because paint and thinner can damage the materials used in the helmet construction. A helmet damaged weakened by a paint agent may not provide head protection in an accident resulting in serious personal injury or death. If you must paint your helmet, please consult your LS2 dealer.

**10**

**Remember: helmets block important sounds and reduce awareness of environmental changes.**

When you wear a helmet, especially a full-face type, you are somewhat isolated from the environment around you. Weather changes can catch you unprepared: sudden showers or temperature variations, as you enter or leave tunnels or climb mountain roads can cause unexpected misting of your shield and loss of visibility. Do not drive with a fogged face shield. Wearing a helmet also reduces your ability to hear traffic sounds, especially at high speeds. With a full-face helmet, opening and closing the shield makes a major difference in how much you can hear. For safe riding be aware of how your helmet type, your speed, affects your perception of road conditions and whether your shield is open.



00211